



DATASHEET

of SAW Devices

SAW Filter

Automotive telematics

Part Number: SXCF1176TBNSC11

- Package Dimensions
- Testing Environment
- Electrical Characteristics
- Frequency Characteristics
- Remark and Packing
- Description

SAW Components	SAW Filter
SAW Filters	SXCF1176TBNSC11

Revision Record

Revision Number	Date	Description
SXCF1176TBNSC11_V1.0	2025-06-16	Version 1.0
SXCF1176TBNSC11_V1.1	2025-06-19	Version 1.1(DC Voltage)
SXCF1176TBNSC11_V1.2	2025-07-22	Version 1.2(Marking)
SXCF1176TBNSC11_V1.3	2025-07-25	Version 1.3(Features&Marking&Description)

Features

- Package size 1.1 x 0.9 x 0.6(max.) mm³
- RoHS compatible
- Electrostatic Sensitive Device (ESD)
- Moisture Sensitivity Level 2
- AEC-Q200 qualified component family
 (Grade 2: -40°C to +105°C)

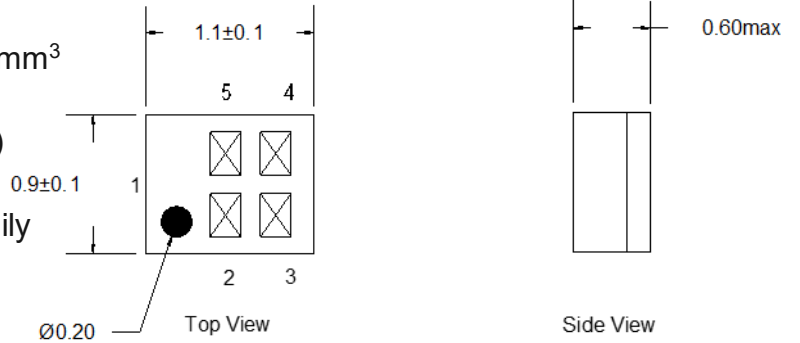

Pin Configuration

- 1 Unbalanced port
- 4 Unbalanced port
- Others: GND

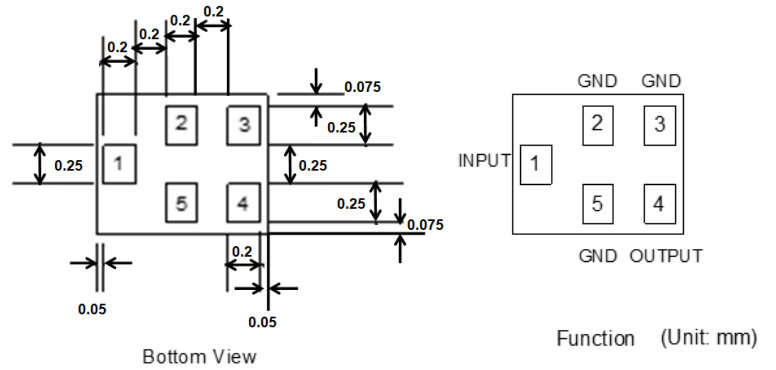

Marking

- XX(The first row): JN
- XX(The second row): Date Code
 (Please refer to the last page for the information of Date Code.)

Measurement Circuit (Top Thru View)

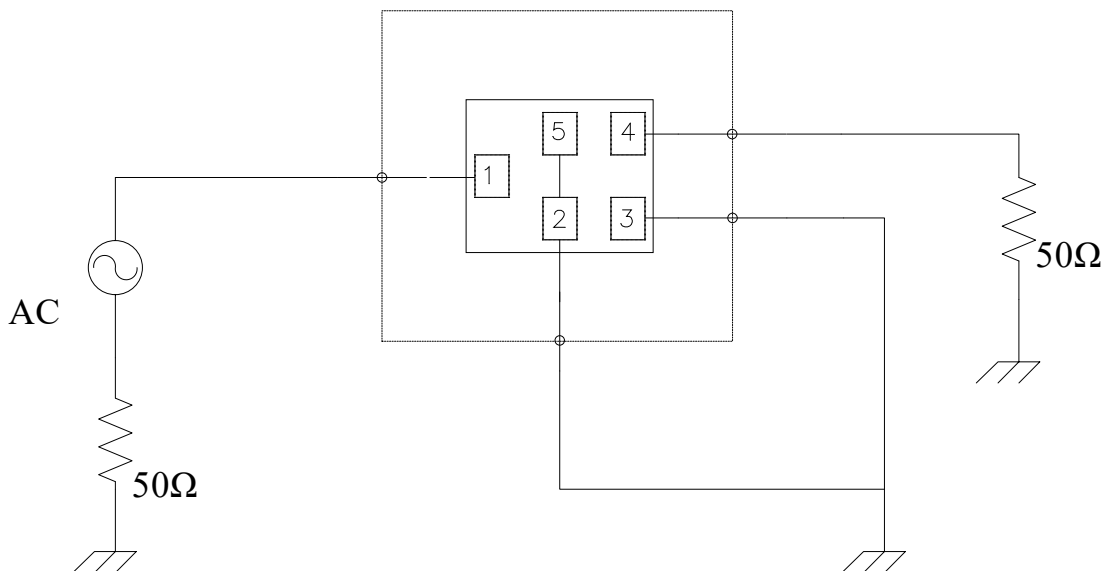

Maximum Ratings

Characteristics		Ratings	Unit
Operable Temperature Range	T	-40 to +105	°C
Storage Temperature Range	T _{stg}	-40 to +105	°C
DC Voltage	V _{DC}	5	V
Input Power Level	P	10	dBm
ESD Voltage(MM)	V _{MM}	50	V
ESD Voltage(HBM)	V _{HBM}	175	V

Characteristics

Temperature range for specification: -40°C ~ +105°C

Terminal source impedance: 50Ω

Terminal load impedance: 50Ω

Item	Frequency Range [MHz]	Characteristics			
		min.	typ.	max.	Unit
Insertion Loss	1166.22 - 1186.68	-	1.5	2.2	dB
Amplitude Ripple	1166.22 - 1186.68	-	0.5	1	dB
Input VSWR	1166.22 - 1186.68	-	1.5	2	
Output VSWR	1166.22 - 1186.68	-	1.5	2	
Absolute Attenuation	698 - 960	33	38	-	dB
	1427 - 2200	34	40	-	dB
	2400 - 2690	40	46	-	dB
	3400 - 3800	40	46	-	dB
	4400 - 5950	29	34	-	dB

1. Evaluation Board Feed line loss is de-embedded.

Frequency Characteristics

Narrow Span

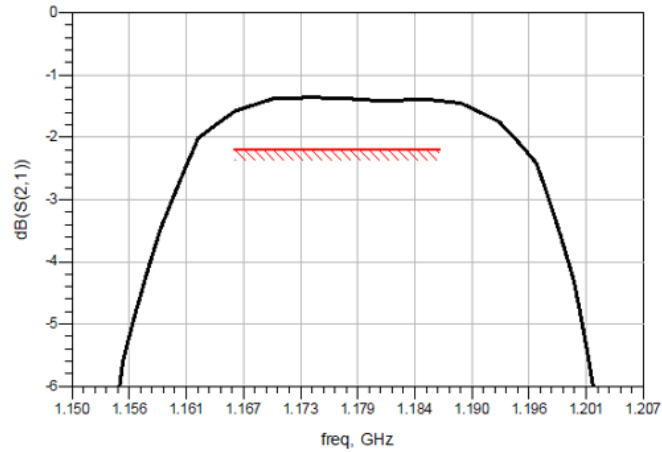

Middle Span

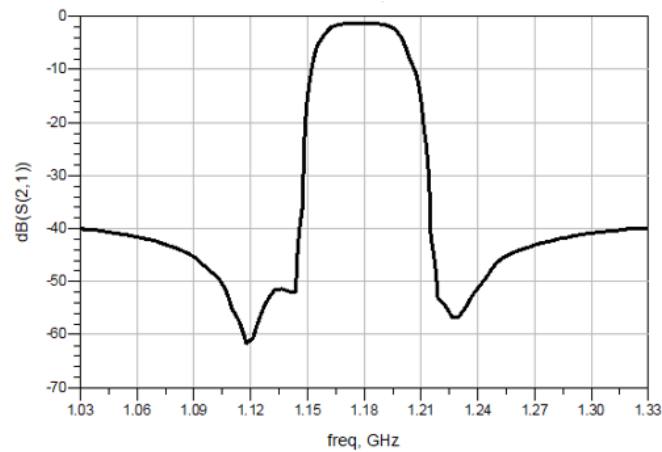

Wide Span

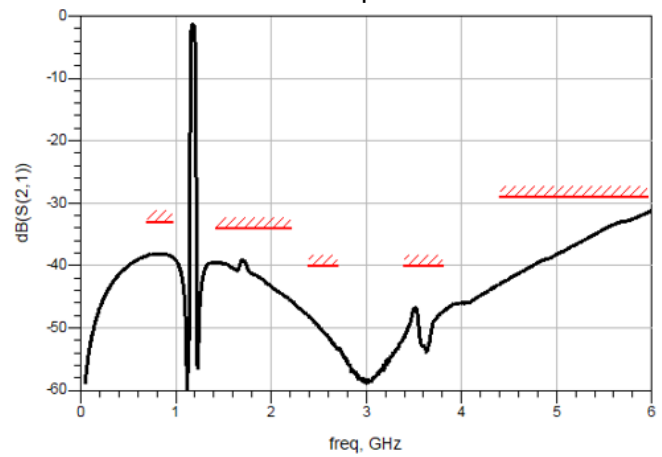

S11 VSWR

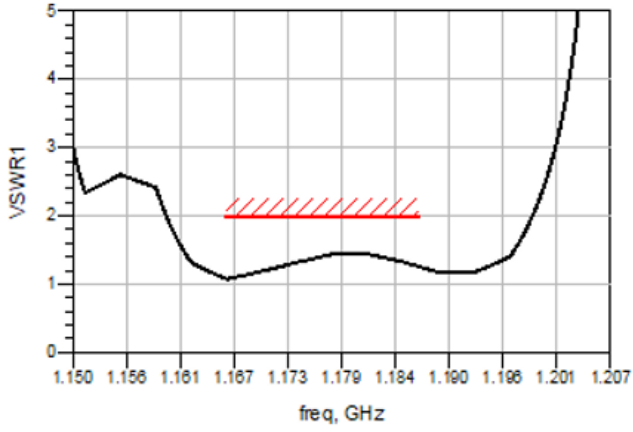

S22 VSWR

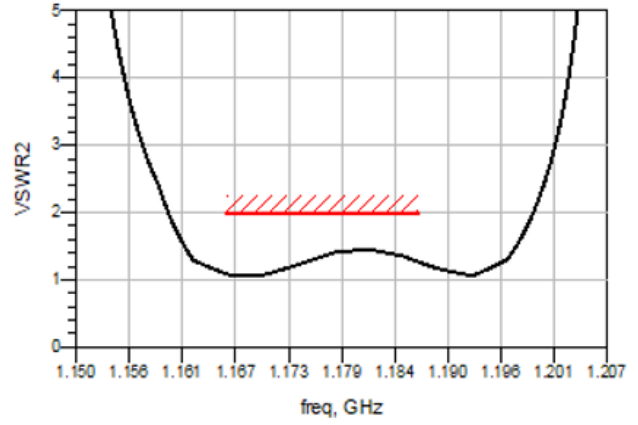

S11 Smith Chart

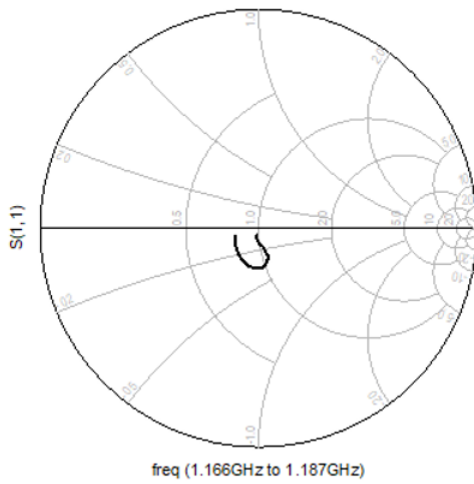

S22 Smith Chart

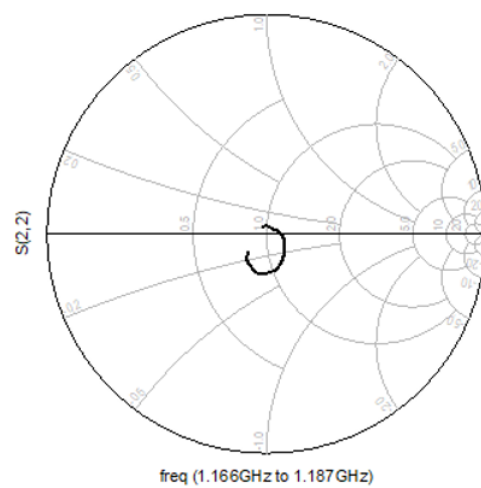

Remarks

1. Please be certain not to apply voltage above the rated voltage of SAW components.
2. Please be sure that the components are operated within the specified operating temperature range.
3. Abrupt temperature change shall be avoided because deterioration of the component characteristics can occur under that situation.
4. Please be careful of soldering temperature when soldering.
5. Please do not place soldering iron on the body of components.
6. Please be careful not to subject the terminals or leads of components to excessive force.

Packing Information

Tape(Unit: mm)

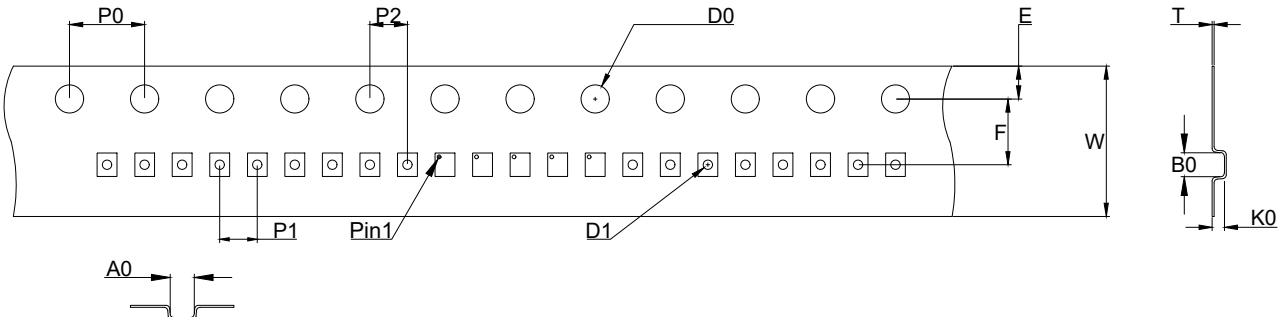

Size	P0	P1	P2	D0	D1	E	F	W	A0	B0	K0	T
Value	4.00	2.00	2.00	Φ1.50	Φ0.50	1.75	3.50	8.00	0.95	1.15	0.68	0.20
Tolerance	±0.10	±0.10	±0.05	±0.10	±0.10	±0.10	±0.05	±0.30	±0.05	±0.05	±0.04	±0.03

Reel: 10000pcs/Reel(Standard Size)

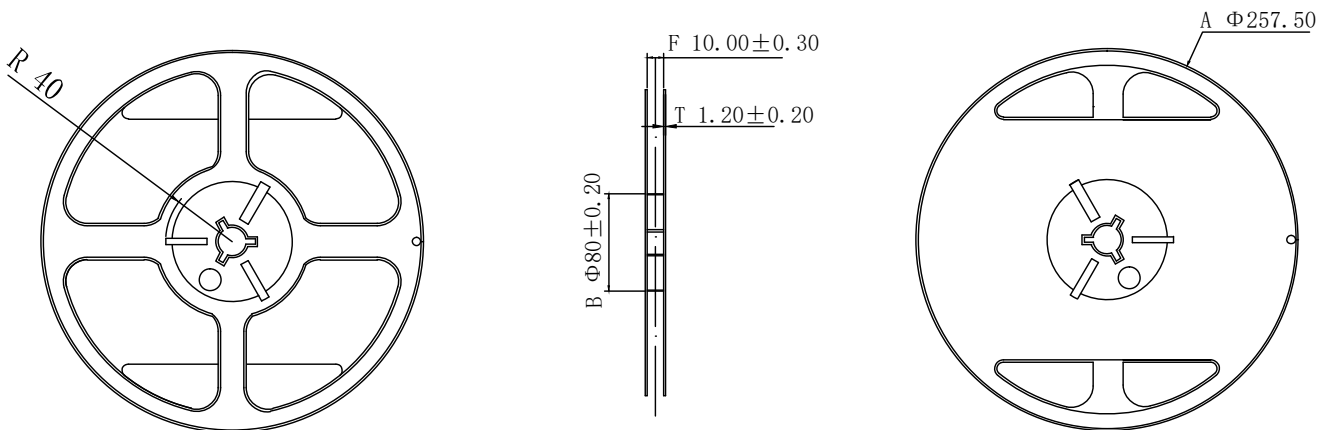

Description of Date Code

A. Month Code:

2022	Jan.	Feb.	Mar.	Apr.	May.	Jun.	Jul.	Aug.	Sep.	Oct.	Nov.	Dec.
2026	A	B	C	D	E	F	G	H	J	K	L	M
2030												
2023	Jan.	Feb.	Mar.	Apr.	May.	Jun.	Jul.	Aug.	Sep.	Oct.	Nov.	Dec.
2027	N	P	Q	R	S	T	U	V	W	X	Y	Z
2031												
2024	Jan.	Feb.	Mar.	Apr.	May.	Jun.	Jul.	Aug.	Sep.	Oct.	Nov.	Dec.
2028	a	b	€	d	e	f	g	h	j	k	l	ṁ
2032												
2025	Jan.	Feb.	Mar.	Apr.	May.	Jun.	Jul.	Aug.	Sep.	Oct.	Nov.	Dec.
2029	n	O	ṑ	q	r	ş	t	ū	ÿ	w	ÿ	y
2033												

B. Date Code:

1	2	3	4	5	6	7	8	9	10	
A	B	C	D	E	F	G	H	J	K	
11	12	13	14	15	16	17	18	19	20	
L	M	N	P	Q	R	S	T	U	V	
21	22	23	24	25	26	27	28	29	30	31
W	X	Y	Z	a	b	€	d	e	f	g

Recommended Soldering Profile

